



# Merida RF

Convector

Operating and Installation Instructions

(Read these instructions carefully and retain for future reference)

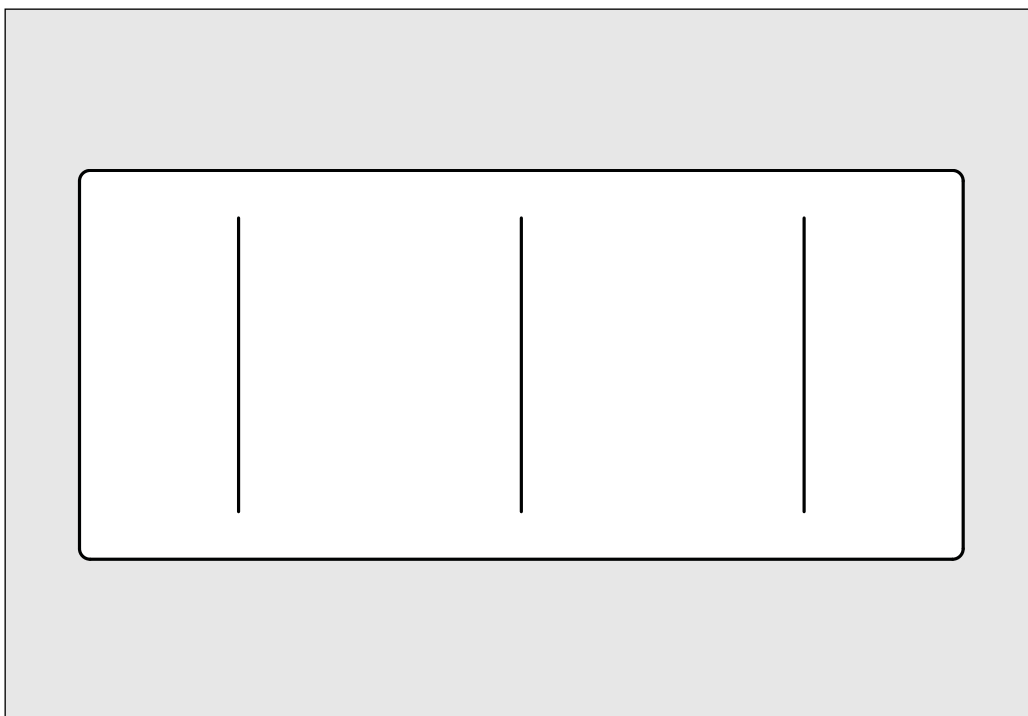

## Models:

**MER500**  
**MER750**  
**MER1000**  
**MER1500**  
**MER2000**

## NOTE:

A qualified electrician must carry out the electrical installation of this convector. The Electrical installation must comply with the current UK and Irish regulations. Any claim on the warranty could be invalid if these requirements have not been met.

# **CONTENT**

IMPORTANT INFORMATION . . . . .	3
TECHNICAL DATA. . . . .	5
GENERAL INFORMATION . . . . .	5
INSTALLATION INSTRUCTIONS . . . . .	6
Electrical Connection . . . . .	6
Location . . . . .	6
Mounting The Heater . . . . .	7
CONTROL OPTIONS . . . . .	7
OPERATING INSTRUCTIONS . . . . .	8
Manual Programming . . . . .	9
Set program temperatures . . . . .	9
Setting the time and date. . . . .	9
Entering a program . . . . .	10
Boost . . . . .	11
Display settings . . . . .	11
Programming with App. . . . .	12
Keypad Locking (Anti-Tamper) . . . . .	12
Advanced settings . . . . .	12
Password . . . . .	14
Runback mode. . . . .	14
Error codes . . . . .	16
Troubleshooting . . . . .	16
Default Values . . . . .	17
ECODESIGN TABLE . . . . .	18
NOTES PAGE . . . . .	19
MAINTENANCE AND CARE . . . . .	20
GUARANTEE . . . . .	20
CORRECT DISPOSAL OF THIS PRODUCT . . . . .	20

## IMPORTANT INFORMATION

- This appliance can be used by children aged 8 years and above and persons with reduced physical, sensory or mental abilities or lack of experience and knowledge, if they have been given supervision or appropriate training regarding the use of the device in a safe way and they understand the dangers involved.
- Children should not play with the appliance. Cleaning and maintenance should not be performed by unsupervised children.
- Children under 3 years should be kept out of reach of the appliance unless they are constantly supervised.
- Children between age 3 and younger than 8 years old should only turn on / off the device whenever it has been placed or installed at its normal operating position provided they are supervised or have received instructions concerning use of the appliance safely and understand the risks that the device has. Children from 3 years and under 8 years old should not plug in, regulate, clean the appliance or perform maintenance.
- Warning: Some parts of this product can become hot and cause burns. Pay particular attention when children and vulnerable people are present.
- Heaters must be installed correctly following the specific requirements of the Installation Instructions section below.



**Warning: in order to avoid over heating the unit, do not cover the heaters. This symbol “DO NOT COVER”, is placed on the convector as a reminder to the user.**

### ATTENTION:

- The heaters must not be covered by clothing, containers or any other objects that may block the air ventilation.

### VERY IMPORTANT:

The “OFF” indicator shown on the heater’s control panel does not mean disconnection of the heater from the power supply and should be understood as a standby condition. To ensure the heater is completely off and without access to the power supply, it is recommended to disconnect it from the power supply by removing the fuse from the spur outlet. Alternatively, change the mechanical switch on the side of the heater to “OFF”.

- The unit must be placed away from flammable objects and children must not be left unattended when the convector is heating.
- The heater should not be located underneath any electrical connection.
- The electric supply line should be protected with a high sensitivity differential device (RCBO).
- Do not use the heater to dry clothes.
- Heaters must not be installed in places where there are risks of splashes such as next to bathtubs, sinks, etc.
- If the power cord is damaged, it must be changed by the manufacturer, its after-sales service or persons qualified to do so, to avoid possible danger
- Anyone who is in the bathtub or shower should not have access to the switches or other power operation devices. Always keep at least 0.6m (UK) or 3.0m (Ireland) between the radiator and the bath or shower.  
(UK: Outside zone 2, Ireland: Outside zone 3)
- The radiator must be installed so that around the radiator there is sufficient space for proper circulation of hot air, with a minimum distance of 150 mm to curtains, furniture, etc

- All repairs where required must be completed by the manufacturing company or by special authorised staff.
- If the heater is sold without cable and plug or any other disconnecting method, the installer must incorporate a disconnecting device taking into account the specific regulations that apply.
- This heater has been designed and created as a fixed heating device and must be used for this purpose only.
- The heater must be mounted directly to the wall using the brackets supplied with the heater.
- Do not place the heater directly on the floor.
- Make sure that the wall where the heater is going to be mounted is suitable to bear the heater's weight.
- Use the correct fixing for the type of wall the heater is to be mounted onto.
- Make sure that the electrical power supply corresponds to the information indicated on the heaters rating plate.
- The heater must be levelled correctly both vertically and horizontally.
- When the heater is operational, the power cord must be totally unrolled and must not touch the surface of the unit.
- Do not operate the heater with wet hands.
- Before undertaking any type of maintenance, ensure that the heater is disconnected from the power supply by removing the fuse from the spur outlet.
- For indoor use only.

## TECHNICAL DATA

MODEL	Power Rating (W)	Size (mm) HxWxD	Net Weight (Kg.)	Fuse Rating
MER500	500	443 x 530 x 125	5.7	5 Amp.
MER750	750	443 x 530 x 125	5.7	5 Amp.
MER1000	1000	443 x 625 x 125	6.2	10 Amp.
MER1500	1500	443 x 810 x 125	7.9	10 Amp.
MER2000	2000	443 x 1000 x 125	9	10 Amp.

## GENERAL INFORMATION

The Merida convector has a special body specifically designed to ensure the maximum rate of heat convection; the air circulation channels provide a very efficient convection effect.

The aluminium heating element ensures maximum heat output.

Designed and fabricated in accordance with EN 60335-1, EN 60335-2 and EN 55014 (regulations for domestic appliances)

- Standard colour White (RAL 9016)

- Class I

- Wall mounted (by quick fixing system)

- On-off main switch

- Overheat protection

- Key-pad locking optional code lock(anti-tamper)

- NTC electronic sensor

- Fitted with mains power cable approximately 1450mm long (without a plug)

- Lithium battery CR2032

# INSTALLATION INSTRUCTIONS

## ELECTRICAL CONNECTION

A qualified electrician must carry out the electrical installation of this convector. The electrical installation must comply with the current UK and Irish regulations. Any claim on the warranty could be invalid if these requirements have not been met.

The convector requires a 220/240V 50/60Hz power supply, a Fused Spur must be included in the wiring to the heater.

Connecting wires:

**Brown: Live**

**Blue: Neutral**

**Yellow-Green: Earth**

The connecting wires must be of the appropriate cross section, with regards to the length of cable, type of cable and power rating of the heater (Refer to your installing electrician for details).

The Merida Heaters must be connected to the fixed wiring of the premises using a **fused** connection box fitted with the appropriate sized fuse for the convector – see Technical Data on Page 5. If the fused connection is also switched, the switch should provide a double pole disconnection with a minimum of 3mm contact gap. The circuit should be protected by an appropriately rated circuit breaker or RCD and if this heater is installed in a bathroom it *must* be supplied from a circuit that is protected by a high sensitivity RCD with a maximum rating of 30mA.

We recommend that the connection box is positioned 10cm to the right of the heater and 15cm above the floor.

## LOCATION

The ideal place to site the heater is as close as possible to coolest wall in the room but it is not recommended to site the heater on un-insulated exterior walls, in this case, the part of the wall behind the heater should be insulated.

In bathrooms, the heaters must not be sited inside the protected area. The control unit switches must not be reachable, directly or indirectly, by a person in the bath or shower.

The heater, under no circumstances, should be installed below an electric power point.

Choose the location of the heater with respect to the minimum distances that are indicated in Figure 1 (Right).

Note: If a window sill protrudes less than 20mm the gap above the heater can be reduced to 10mm.

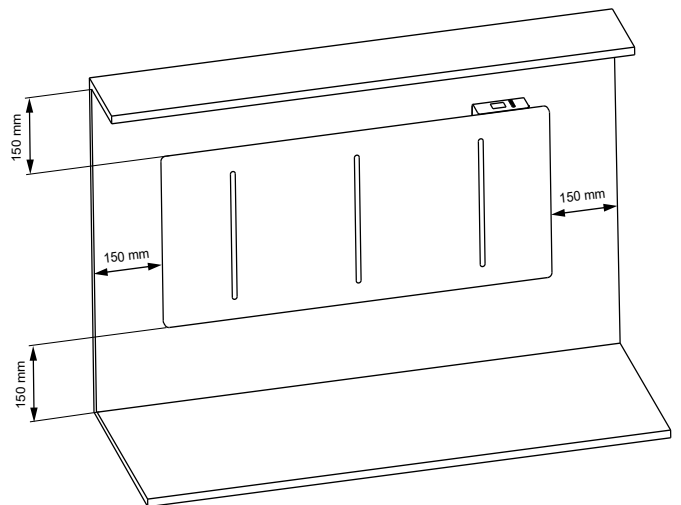

Fig. 1: *minimum distances*

## MOUNTING THE HEATER

In order to mount the heater on the wall, first attach the mounting bracket supplied with the appliance to the wall.

Remove the bracket attached to the back of the heater by pressing on the two clips on the top of the bracket to release them from the upper holes on the back of the heater. Once the upper bracket is released, withdraw the lower part of the mounting bracket. See Figure 2.

1. Stand the mounting bracket on the floor and measure the distance from the wall using the information in *Table 1* below. Mark the top holes, as shown in Figure 3a.

Remove the bracket and drill and plug the wall for the fixing screws.

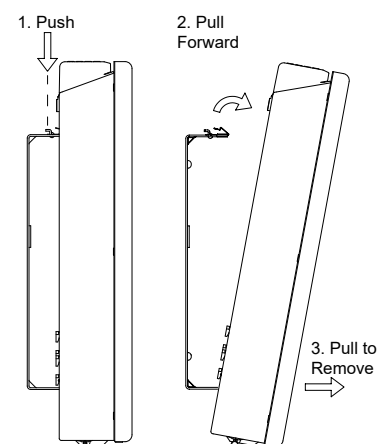
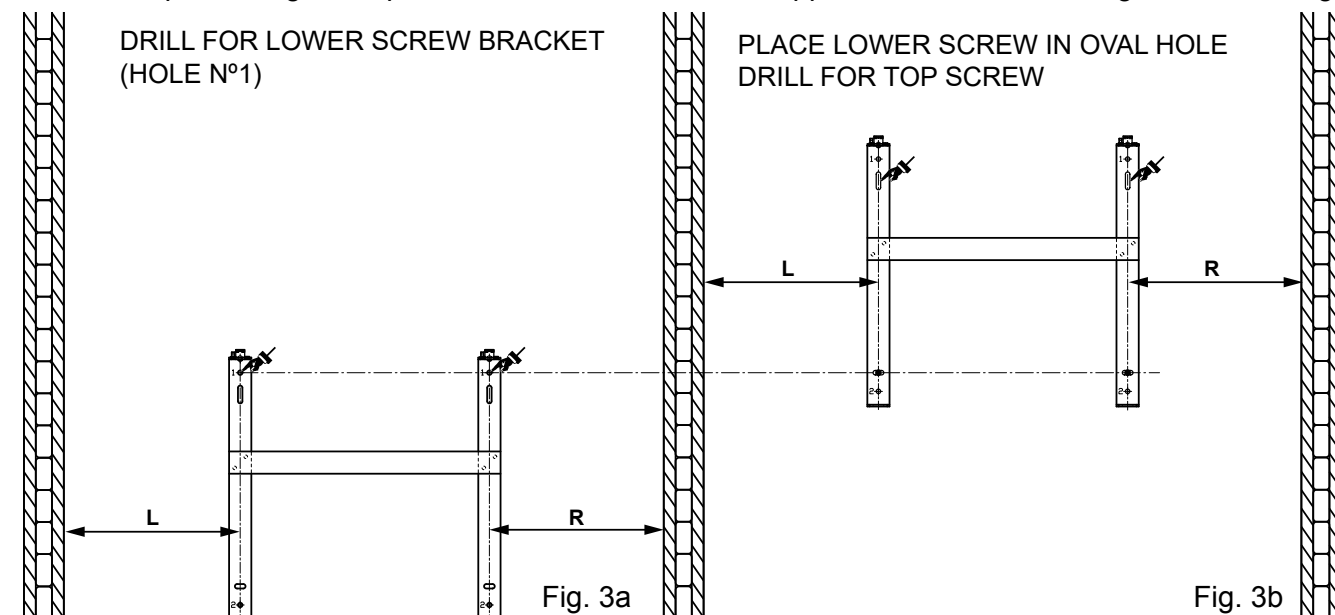

Fig. 2

- Attach the mounting bracket to the wall using the screws provided, screw through the lower horizontally slotted holes and mark through the upper vertically slotted holes for the top fixing screws. See Figure 3b. Drill and plug the wall for these screws.  
Using this method the heater will be mounted on the wall with 200mm between the floor and the bottom of the heater.

- When the mounting bracket is fixed to the wall mount the heater by first attaching the lower bracket and then the top ensuring the clip clicks into the heater, once clipped in, attach the locking screw. See Fig 4.



MODEL	L (mm)	R (mm)
Merida 500	130 + d	130 + d
Merida 750	130 + d	130 + d
Merida 1000	72,5 + d	72,5 + d
Merida 1500	180 + d	150 + d
Merida 2000	260 + d	260 + d

**Table 1.**

**d:** distance between edge of the heater and wall (minimum 150mm).

NOTE: The bracket for the 1500w heater is not in the centre of the heater, ensure proper measurement prior to mounting.

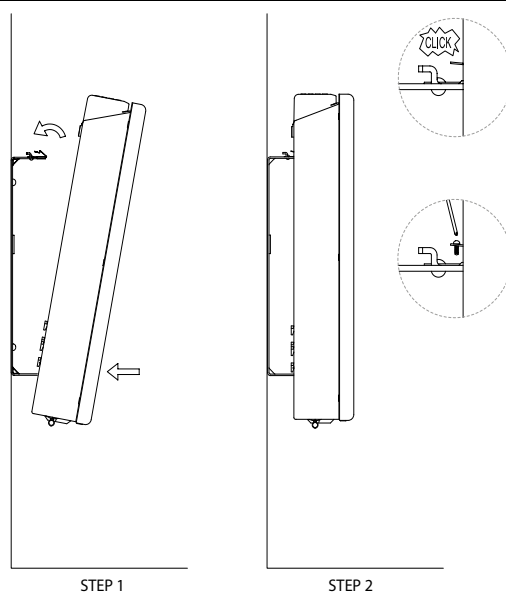

## CONTROL OPTIONS

The Merida convector is designed to be used in conjunction with the Smart Gateway system and App, providing total control of your heating system from anywhere in the world via the internet. The App is available for both Android and iOS devices and offers the ultimate in control and energy monitoring.

**Search for “Tevolve” on the either the Google Play Store or the Apple App Store.  
Scan this QR code to access to the download.**

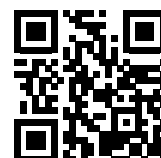

It is also possible to programme each convector individually without the App by using the built in controls and screen. This may be convenient for single heaters however we recommend the Gateway to control multiple heaters.

Finally the heaters can be used in Manual mode or Easy mode which bypasses any programming and provides simple On/Off operation.

# OPERATING INSTRUCTIONS

The control is based on four buttons and a TFT display.

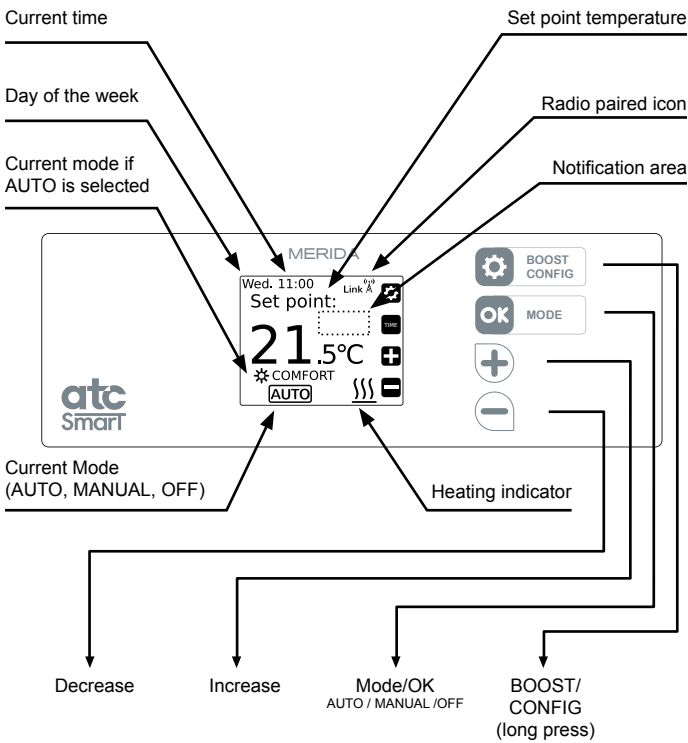

## Merida Convector Controls

Note: The 4 symbols on the side of the screen will change depending on the menu that the user is accessing.

**i** The first press of any button will wake up the convector any further button presses will activate the function required.

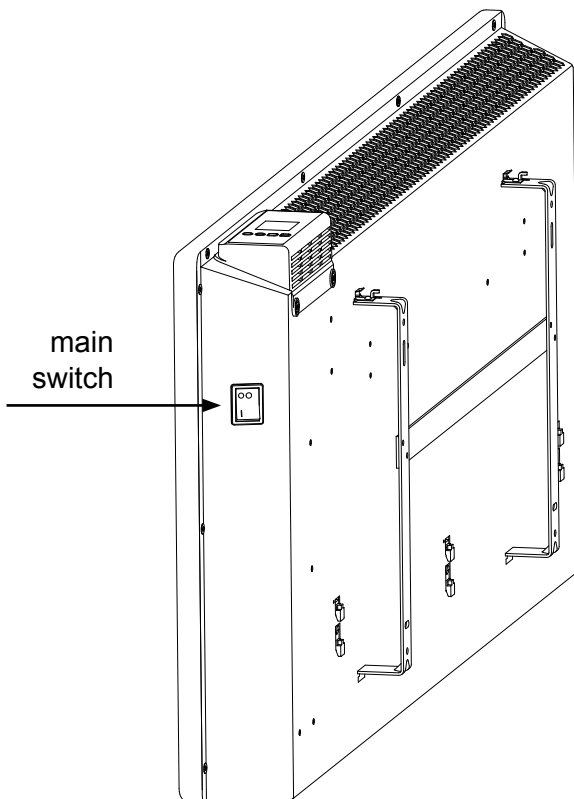

## Switching ON (Master):

Once the convector has been mounted on the wall and correctly connected to the mains electricity power supply, press the main On/Off switch on the right hand side of the convector.

After around 3 seconds the screen will show various information and the convector is ready to operate. It is recommended to leave the convector on and use the standby function (below) to turn the convector off when it is not required.

## Switching OFF (Master):

To switch off the convector press the main On/Off switch on the right hand side of the convector. The TFT screen will turn blank and the convector will lose any connection with the Gateway.

## Stand-by function:

From any "On" screen press the OK/Mode button until the **OFF** symbol is present as shown in the following screen.

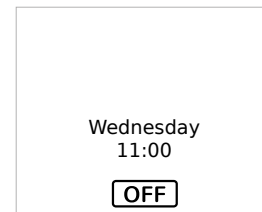

When the convector is in Stand-by Mode it will retain programs and continue to communicate with the Gateway (if connected) but will not heat.

To switch the convector on again, press the MODE button to choose programme mode (**AUTO**) or manual mode (**hand icon**) you will see the following screens:



In any of the operation modes the area above the temperature set point may display a message showing the status of the convector, see the following screens:

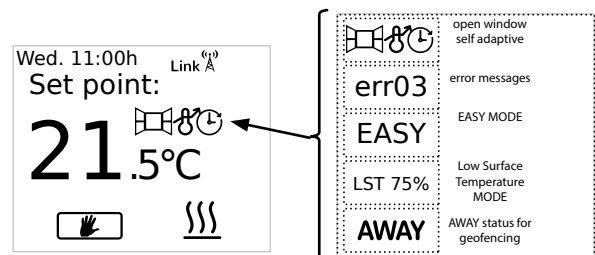

## MANUAL PROGRAMMING

To assist with programming the TFT screen is backlit and will stay illuminated for approximately 10 seconds after the last button is pressed. (To change the backlight time, see the section on DISPLAY)

When the convector is operational and the room temperature is lower than the set temperature the heating symbol will be shown indicating that the convector is producing heat. When the room temperature equals or is above the set temperature the heating symbol will not be present indicating the convector is not producing heat.

The following screens show **OFF**, **AUTO** and **MANUAL** modes. To change between the different modes press **OK/Mode** button.

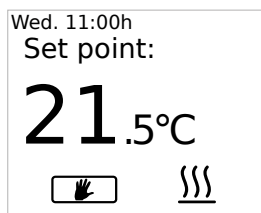
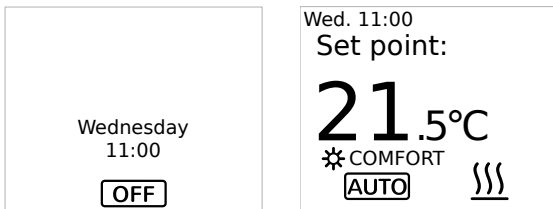

When the convector is in **AUTO** mode the temperature can be adjusted by pressing the +/- buttons. This change will remain active until either the next programme change or until midnight when the temperature will revert to the preset value.



When the temperature has been adjusted in AUTO mode a hand will show beside the auto to symbol to show the amended set-point.

To manually return the heater to the set-point, cycle the modes until returning to AUTO.

Use the +/- keys to set the temperature when the convector is in **MANUAL** mode.

NOTE: To rapidly change the temperature set-point in any mode press and hold the +/- keys.

## SET PROGRAM TEMPERATURES

To amend the temperature set points used in the program mode, press and hold the CONFIG button until the following screen appears:

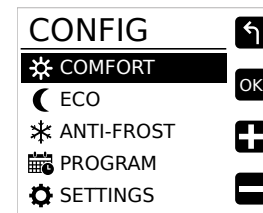

Select either Comfort, Eco or Anti-Frost and press OK to enter the menu.

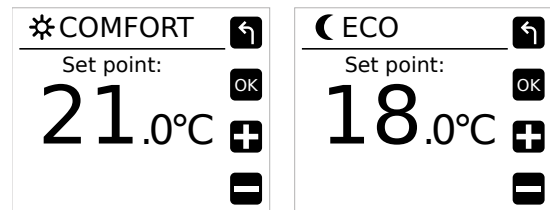

Press the +/- button to change the temperature of each mode then press OK to confirm and return to the main operation screen, repeat the above to set the other program temperature set-points.

## SETTING THE TIME AND DATE

If a convector is paired with a Gateway then the local time from the internet is automatically applied to the convector.

To set the Clock on an unpaired Convector, press and hold the CONFIG button until the CONFIG menu is shown and then select SETTINGS, press OK and then select TIME Settings and press OK again.

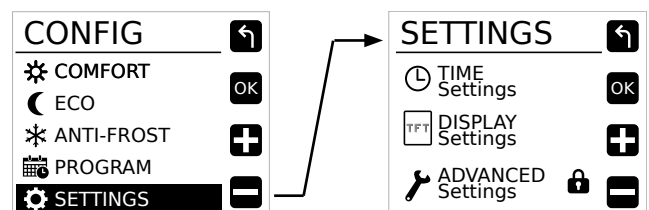

In the TIME menu the Time, Date and Daylight Savings (DST) can be set.

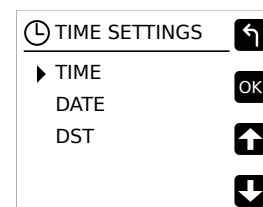

Select TIME and press OK.

The current set time is shown on the display, to change time move the underline to the Hours and press OK.



The hours will flash, use the +/- keys to adjust to the correct value and press OK, move to the minutes and repeat to set the correct time. Once complete press the CONFIG button to exit.

To set the Date select the Date menu, press OK and enter the Day, Month and Year.

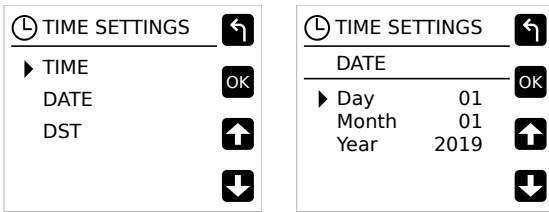

To exit the Date menu, press the CONFIG button.

The Convector can automatically adjust the time offset for Daylight savings. To set this option on or off choose ON or OFF in the DST menu.

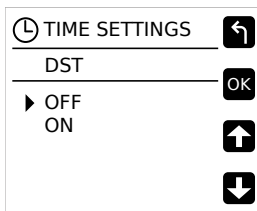

## ENTERING A PROGRAM

The AUTO mode of the Merida convector allows you to run a program designed to accommodate your lifestyle. To enter a new program into the Heater press and hold the CONFIG button until the CONFIG menu appears, then use the +/- buttons to select PROGRAM and press OK.

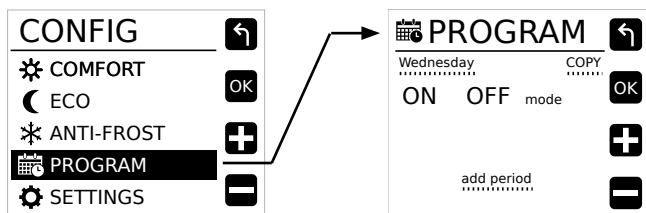

To enter a program into the convector first select the day of the week in the upper left corner of the programming screen and press OK, change the day to the day you want to program and press OK.

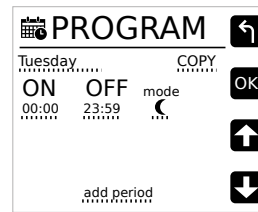

Once the correct day is selected, select add period and press OK. The underline will change to a box around the times that can be changed. Press OK and the ON time will begin to flash.

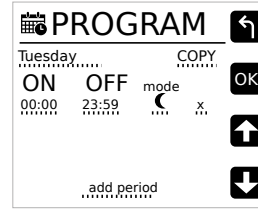

Change the On time to the starting time the convector should heat (7:00 in our example), press OK and the OFF time starts to flash. Change the OFF time to the end of the heating period required (e.g:12:00).

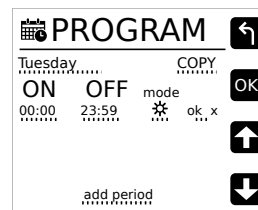

Once the Times have been Entered, chose the temperature set point required for the heating period; either Comfort ☼ or Economy ☾ (Set above).

Any time periods outside of Comfort or Economy are automatically set to Anti-Frost ❄.

Once the set point is chosen choose either "OK" to save the setting or "x" to delete.

Extra heating times can be added by selecting "add period" and repeating the above procedure.

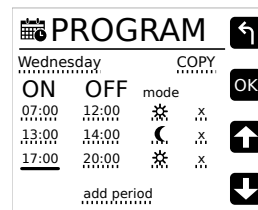

Once the program for the day is complete, it can be copied to other days in the week by selecting COPY from the programming screen.

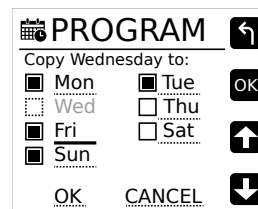

The copy screen will appear and the day that is being copied from will not be available. (Wednesday in the example.)

Select the days to copy to and then move the underline to "OK" on the screen and press the OK button.

The screen will change back to the program menu.

To Exit press CONFIG or leave the convector and the display will revert to the current running mode.

To make sure your program is running Press the OK/MODE button until **AUTO** is shown at the bottom of the screen.

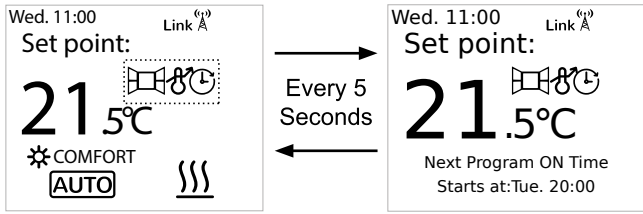

The screen will change between the operation screen and the next time of operation. At any time, the temperature can be changed with the +/- buttons.

### BOOST

The Merida convector has a built in Boost mode to allow the user to temporarily over-ride the current operating mode. The Boost button (short press of CONFIG) will immediately turn the heater on for 1 hour at 21°C (or the previous boost setting) as soon as the button is pressed.



To adjust the temperature of the boost period, use the +/- buttons.

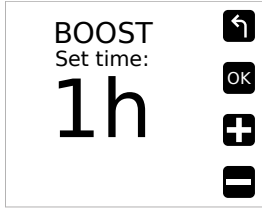

To adjust the duration, press the CONFIG button, the boost time setting screen will be displayed; adjust the time required between 1 hour and 24 hours.

To return to the boost screen press CONFIG. To return to normal operation and cancel from the Boost mode Press the OK button.

### DISPLAY SETTINGS

The Display menu on the Merida convector allows the user to customise how the convector looks whilst the screen is on and off, it also allows the button sound to be controlled.

To open the DISPLAY menu, press and hold CONFIG until the menu appears, select SETTINGS and press OK, finally select DISPLAY and press OK.

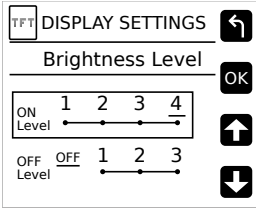
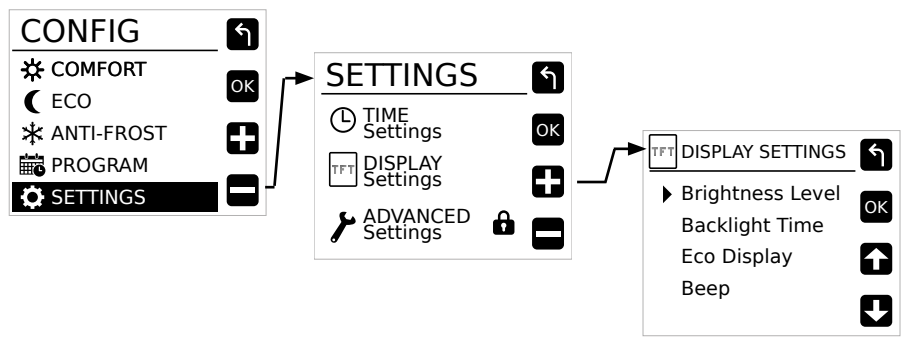

To Adjust the brightness of the screen, select Brightness level and press OK.

The ON levels are between 1=25%, 2=50%, 3=75% & 4=100%.

The OFF levels are Off, 1=3%, 2=10% and 3=20%. Chose the level required and Press OK.

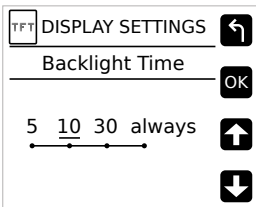

To Set the time the screen stays on for after the last button press, select Backlight Time from the DISPLAY menu and chose how many seconds are required. The factory default is 10s (Always is used for Demonstration and will never turn off)

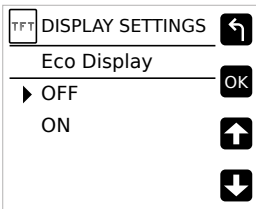

The Merida convector features a "responsible consumption" Eco Display mode, this mode will show a coloured bar across the bottom of the screen to encourage the user to set an economical temperature. This feature is turned on and off in the ECO DISPLAY menu.

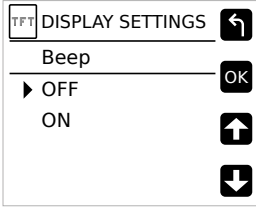

To de-activate the beep when each key is pressed enter the BEEP menu and select either On or Off.

**i** The first press of any button will wake up the convector any further button presses will activate the function required.

## PROGRAMMING WITH APP

To programme a Merida convector with a Gateway the heater must be paired to the Gateway. In order to complete this operation the pairing/discovery mode of the Gateway should be activated. To complete this process, press the Link button on the Gateway for 2 seconds. (*Details of this procedure can be found in the Gateway instruction manual*).

Once this is done, press and hold the **OK** button on the Merida for 3 seconds while the convector is in one of the main modes (OFF, AUTO, MANUAL).



Once the pairing process completes the display will show "Link" with an antenna and then display the same information in the upper right corner of the screen.

The Merida convector is now ready to accept programme instructions from the Gateway/App.

**A Tevolve account is required to use the App, complete the activation process at:**

<http://tevolve.termoweb.net>

If the convector has been linked to the Gateway and for some reason communication is lost, the Link icon disappears and the antenna  starts flashing in red alternating with Link text.

## KEYPAD LOCKING (ANTI-TAMPER)

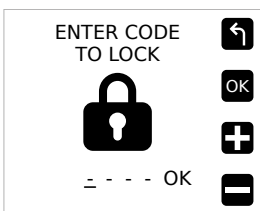

The keypad can be locked to prevent any unauthorised person (children, people in public places, nurseries, offices, hotels etc.) altering the settings of the convector.



A Password is required to lock the keypad (0 0 0 0 by default), See Password Settings Chapter for further details on changing passwords.

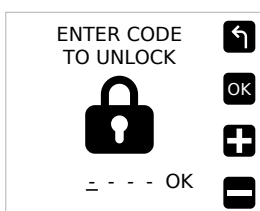

To Lock the convector Press and hold the + and – buttons until the lock screen appears. Enter the password on the screen and press Ok. The screen will change to show the Lock screen and

any button presses will be ignored and the locked screen displayed.

To unlock the keypad press and hold the + and - until the unlock screen appears. Enter the password and press OK. If the incorrect password is entered "INVALID CODE" will be displayed.

When the keypad is locked the convector will still receive communications from the Gateway.

## ADVANCED SETTINGS

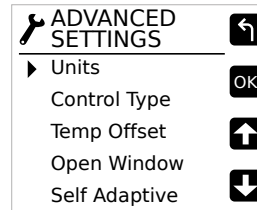

The Advanced settings menu is password protected to prevent any inadvertent changes to the factory settings.

To access the Advanced settings, enter the password (default 0 0 0 0). It is strongly recommended to set a custom password once installation is complete. (For more information see the password section).

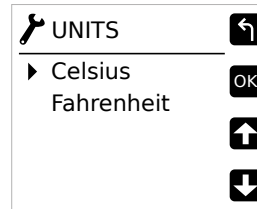

The units menu allows the main temperature units of the convector to be chosen between Celsius (°C) and Fahrenheit (°F).

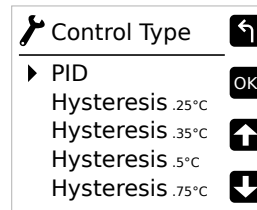

The Control Type menu allows two types of control of the temperature control setting. PID will calculate the best switching point for the heater depending on previous room readings.

Hysteresis is the difference between the detected temperature and the set-point required before the heater will come on. It is not recommended to change these settings.

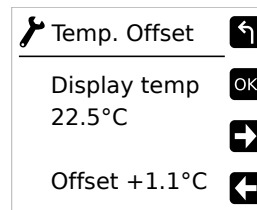

The temperature offset menu allows the display temperature to be adjusted by  $\pm 3^{\circ}\text{C}$ . Adjusting this set-point will affect the operation of the thermostat set-points, changing this setting is only

recommended if the displayed temperature is noticeably different from another sensor in the space.

 The first press of any button will wake up the convector any further button presses will activate the function required.

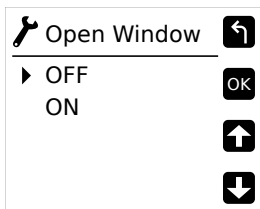

The Open window setting will turn the heating of the convector off if the unit detects a rapid drop in temperature over a short period of time.

To re-activate the heating if the open window function has activated press any button the convector.

If the temperature rises above the minimum detected temperature then the heater will reactivate and turn the

open window function off (i.e. the window was closed).

If this function comes on frequently e.g. in an area where there is an external doorway, it is recommended to turn the open window function off.

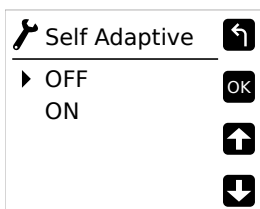

The Self Adaptive setting will allow the convector to calculate the optimum time to start the heating cycle **when running in Program mode.**

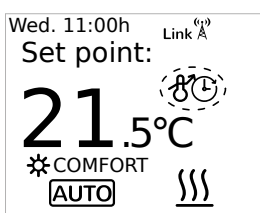

If this setting is turned on it will be shown in the Notification area and the heating will come on before the programmed starting time so that the room is at the correct temperature at the programmed starting time.

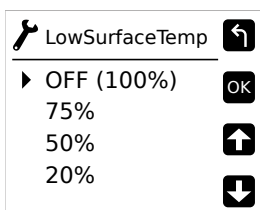

The Low Surface Temperature (LST) menu will allow the output of the heater to be limited to a lower setting to prevent the surface of the heater becoming too hot. If a surface temperature of less than 43°C is required use the lowest setting.

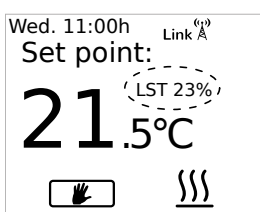

It is recommended that if the LST function is activated then the convector should be locked with a non-standard password after activation to prevent the function being turned off.

(See Password Section for details on changing the factory default password)

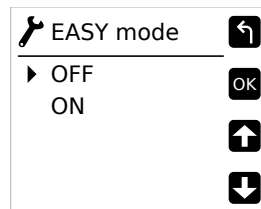

EASY Mode is a simple mode of operation where by only the + and – buttons on the convector operate to increase or decrease the temperature. The OK button is de-activated. To turn the convector on or off use the Main power button on the side of the heater.

When running in Easy mode the screen will show EASY in the notification area to let the user know that the mode is active.

To exit EASY mode press and hold the CONFIG button for 10 seconds, then select “off”.

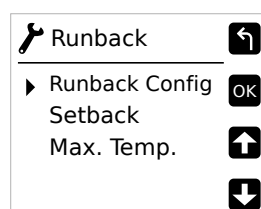
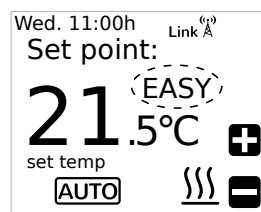

Runback: See Runback Section on page 14

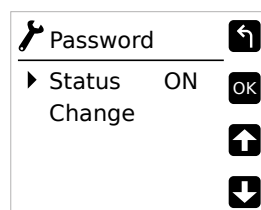

Password: See Password Section on page 14



Resetting the convector will return all settings to the factory defaults and will also delete any ‘pairing’ with a Gateway.

To activate the RESET feature select with arrow buttons OK, and press the OK button.

**i** The first press of any button will wake up the convector any further button presses will activate the function required.

## PASSWORD

The Password Function of the Merida convector serves a number of functions; Keylock, Advanced menu access and also Runback access when the Runback is activated. The Default password from the factory is four zero's (0 0 0 0), however it is **strongly recommended** that once installation is complete that an alternative code is set.

To access the password function enter the ADVANCED SETTINGS menu (see above) and then select PASSWORD.

The password can be turned on or off and changed.

To Turn the password on or off, Select Status and press OK.

Select either "ON" or "OFF" and press OK.

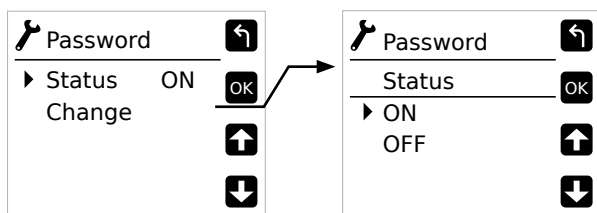

If you are reactivating the password then the Enter New password screen is shown (The password will always default back to 0 0 0 0).

If the password is turned off, the Keylock, Advanced Settings menu and Runback controls are accessible without entering a password.

To Change the password code when the password is active select Change from the password screen and press OK.

Enter and confirm the new password and press OK.

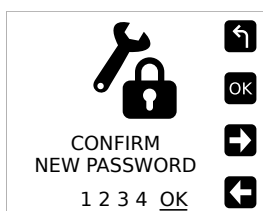
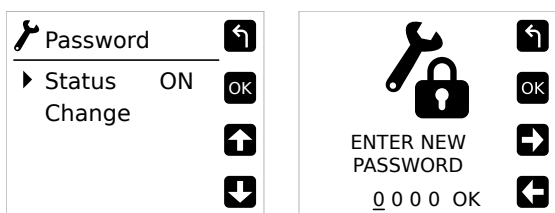

## RUNBACK MODE

The Merida convector comes with a Runback mode for use when the heater will be installed in areas where **restricted** user control is required.

When Runback Mode is active it allows the user to set the convector to run for a specific pre-set amount of time and temperature. It is also possible to set a maximum temperature (Max Temp) above the Runback setting to allow the user to increase the temperature within the limits allowed.

Before activating Runback mode it is strongly recommended that an alternative password is set and activated and the comfort mode temperature set-point is set to 35°C. When the password is activated the user will have no access to any convector settings without the password.

NOTE: Any Display settings will be used in RUNBACK mode, eg. Backlight time and intensity, Eco mode etc. These should be adjusted prior to setting Runback to Active.

After the Runback time period ends the room temperature will return to off (7°C minimum) until the Runback is restarted.

It is also possible to set a minimum temperature to be maintained (Setback) outside of the Runback mode; when setback mode is activated the room temperature will only fall as low as the Setback temp and be maintained at this point until Runback is restarted.

### ACTIVATING RUNBACK MODE

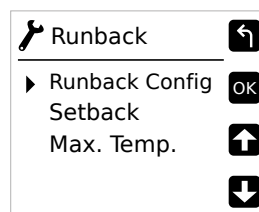

Runback mode is activated from the Advanced settings menu.

The main Runback screen has 3 options:

- Runback Config
- Setback Config
- Max Temp

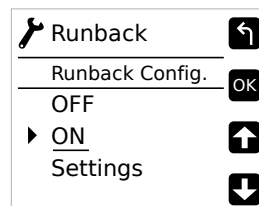

Set Runback to ON to activate the mode.

Note: The Runback settings menu is not available unless the Runback mode

has been turned on.

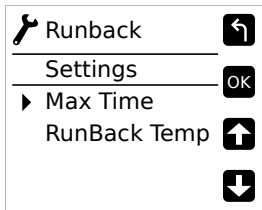

The Default time for Runback to operate is 30 minutes, this can be increased in ½ hour sections up to 8 hours (480 mins) by using the + & - and OK.

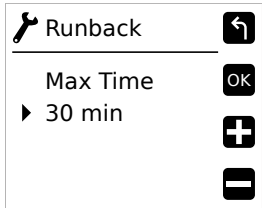

0 → 30 → 60 → 90 → 120 → 150 → 180 → 210 → 240 → 270 → 300 → 330 → 360 → 390 → 420 → 450 → 480 → 0

The time can be limited to any of the above values, when the user activates the Runback timer, they can choose any of the times up to the maximum set on installation. After the Runback has expired the next activation will start at the previous time selected. i.e. If the previous setting was 60min, the next activation will start at 60min.

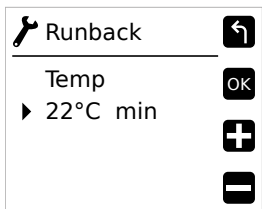

The temperature that the convector runs at when Runback is activated is set in the Runback Temp menu. Use + & - to Set the temperature and Press OK.



Please note that the Runback temperature cannot be set higher than the Comfort setting in the main menu.

## SETBACK

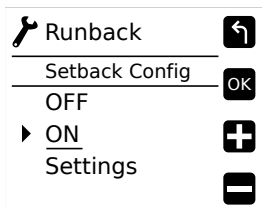

The setback mode can be used to limit the temperature that the area where the heater is installed can fall to outside of the Runback operation.

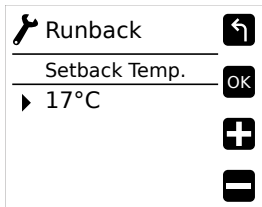

This temperature can be set between 7°C (minimum) and 0.5°C less than the Runback temperature set-point.

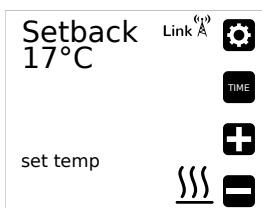

When Setback is operational, the screen will show "Setback" and the set-point.

## MAX TEMPERATURE

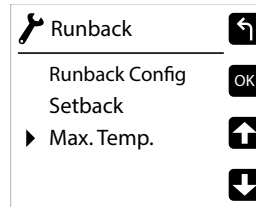

The Max Temperature setting allows the installer to set a temperature higher than the Runback temperature set-point to give the user some leeway in the temperature of the room. Typically this is set 1-2°C higher than the Runback setting.

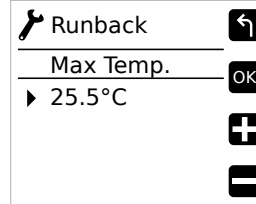

Both the Setback and Max temp are set with the +&- buttons from their respective menus.

The graphs below show typical scenarios for each of the settings.

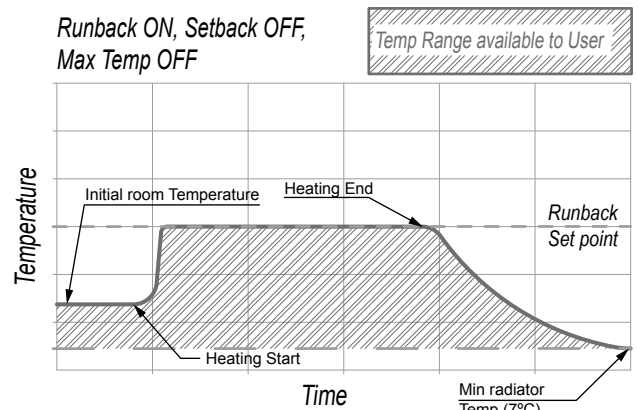

When Setback and Max temp is OFF, the user has a choice between the minimum convector temperature of 7°C and the Runback temp setting.

Outside of the Runback period the temperature will fall as low as 7°C if the convector is not re-activated.

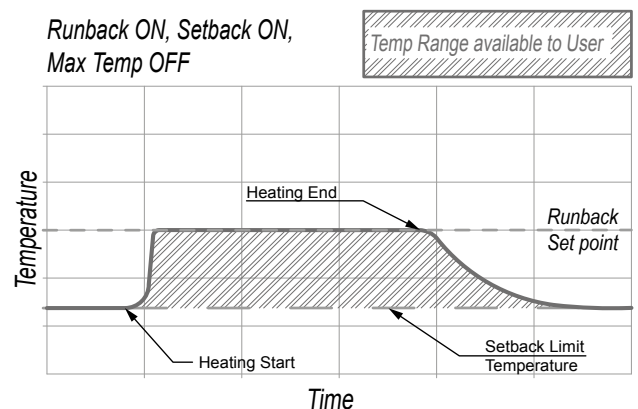

When Runback and Setback are activated then the user has a limited choice of temperature between the Setback setting and the Runback setting.

Outside of the Runback period the temperature will fall to the Setback temperature if the convector is not re-activated. (Building Fabric Protection)

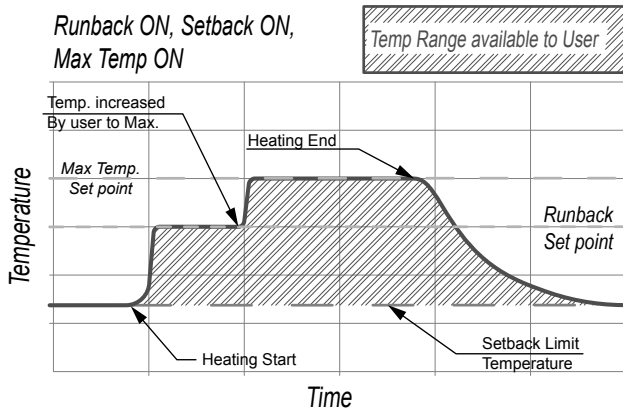

When all 3 settings are activated then the user has a choice between Setback as a minimum and the Max temp setting as a maximum.

The Convector will always come on at the Runback set point.

In the example above the user has activated Runback and then increased the temperature to the Max Temp set point after a time.

## ERROR CODES

The Merida Convector continuously checks to ensure that it is working correctly all the time, however in some cases the convector may display an Error code on the screen.

Below you will find each code and a short description on the cause of each issue.

- E1 Short circuit for Element controller.
- E2 Very High Load >2800w.
- E4 High Temperature in Controls detected.
- OC Disconnected or Open circuit temperature sensor.
- SC Damaged or Short circuit temperature sensor.

When the display shows E2 or E4 the element will be turned off.

If the screen shows E1 the high level cutout will open and turn the element off.

In the case of any error code shown please contact [Technical@ATC.ie](mailto:Technical@ATC.ie) for support; please include an image of your serial number and the Error code with the email.

## TROUBLESHOOTING



If the power of the Lithium battery drops, in every active screen a small icon will remind the user that the battery is flat. The time and date is not retained if the convector main switch is disconnected.

If the convector is paired with an internet connected Gateway the time and date are always updated when the convector reconnects to the Gateway.



When a convector has been paired with a Gateway, the text "Link" and an antenna with flashing waves appears on the top right of the screen.



When the Gateway is not powered or it is too far away from convector, the Link text alternates with a red antenna without waves to alert the user that the convector cannot communicate with the Gateway.

If a convector is paired with a Gateway, and the internet connection is lost the heating system is not accessible from the app.

However the running schedule remains in the convector memory and continues with the last user setting once the lithium battery is not flat.

The Lithium battery (CR2032) life is around 5 years from date of manufacture, this life can be decreased depending storage conditions.

To change the battery contact your installer or an electrician.

## DEFAULT VALUES

Default mode: OFF

Type of control: PID

Temperature offset: 0°C

Open window detection: Disabled

Adaptive Start: Disabled

Programming in one hour intervals,

All programmed hours in anti frost mode

Set point temperatures:

- Anti-freeze 7°C
- Eco 18°C
- Comfort 21°C
- Manual temperature: 21°C
- Boost mode temperature: 21°C
- Boost mode time: 1 hour

Low Surface Temperature: Disabled

Password status: Activated

Password: 0000

Units: °C

Keyboard: Unlocked

Easy mode: Disabled

Runback mode: Disabled

Setback: Disabled

Runback temperatures and defaults:

- Antifreeze: 7°C
- Eco: 18°C
- Comfort: 21°C
- Max. Temperature of Runback: 21°C
- Max time of Runback: 30. Minutes

Screen brightness on: Max (4)

Screen brightness off: Min (OFF)

Screen time on: Min (5s)

Beep: Disabled

EcoDisplay: Disabled

DST: Disabled

Default date: 01-01-2019 (Tuesday)

## ECODESIGN TABLE

Models	MER500	MER750	MER1000	MER1500	MER2000
<b>Heat output</b>					
Nominal heat output ( $P_{nom}$ )	0.500 kW	0.750 kW	1.000 kW	1.500 kW	2.000 kW
Maximum continuous heat output ( $P_{max,c}$ )	0.500 kW	0.750 kW	1.000 kW	1.500 kW	2.000 kW
<b>Auxiliary electricity consumption</b>					
In OFF mode ( $P_o$ )	0.00 W	0.00 W	0.00 W	0.00 W	0.00 W
In standby mode ( $P_{sm}$ )	0.40 W	0.40 W	0.40 W	0.40 W	0.40 W
In idle mode ( $P_{idle}$ )	0.40 W	0.40 W	0.40 W	0.40 W	0.40 W
In network standby ( $P_{nsm}$ )	0.70 W	0.70 W	0.70 W	0.70 W	0.70 W
Standby mode with display of information or status	no	no	no	no	no
Seasonal space heating energy efficiency in active mode ( $\eta_{s,on}$ )	96.0%	96.0%	96.0%	96.0%	96.0%
<b>Type of heat output/room temperature control:</b>	TW, Electronic room temperature control plus week timer				
<b>Other control options:</b>	With open window detection With distance control option With adaptive start control, Working time limitation				
<b>ATC Electrical and Mechanical</b>					
<b>Head Office &amp; Showrooms</b>					
ATC House, Broomhill Drive, Tallaght, D24 EF99, Ireland.					
IRL Tel: +353 (0)1 4625111					
UK Tel: +44 (0)203 5649164					
Fax: +353 (1) 452 0887					
Email: sales@atc.ie					



## MAINTENANCE AND CARE

Merida convector heaters require very little maintenance.

The surfaces of the convector must not be cleaned with an abrasive product or those containing granular substances. We recommend regular cleaning with pH neutral products. In order to clean the convector, it is recommended that the electric power is switched off.

### IMPORTANT

**Failure to keep the Merida Convector clean may result in dust becoming burnt and depositing on the wall above the heater in the form of dark streaks or patches. This type of marking is expressly due to failure to keep the heater and surrounding area clean. ATC take no responsibility for any such damage caused**

## GUARANTEE

Your appliance is guaranteed for 2 years from the date of purchase – during this period we will repair or exchange, at our discretion, any faulty or defective parts providing the appliance has been used in accordance with the operating & installation instructions and has not been misused or mistreated in any way.

Any un-authorized repair or attempted repair will invalidate the guarantee. You may be asked to return the product to our workshop for inspection to establish whether the fault is covered under the guarantee. Transportation charges are not covered under the guarantee.

The guarantee is valid in the UK and Ireland only.

This guarantee is additional to your statutory rights.

In the unlikely event of a problem with your appliance please contact your supplier.

## CORRECT DISPOSAL OF THIS PRODUCT

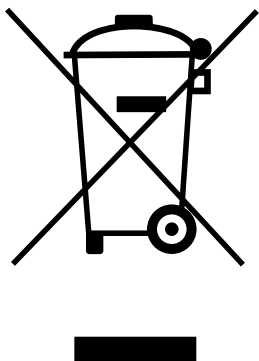

(Waste Electrical & Electronic Equipment)

(Applicable in the European Union and other European countries with separate collection systems)

This marking shown on the product or its literature, indicates that it should not be disposed of with other household wastes at the end of its working life.

To prevent possible harm to the environment or human health from uncontrolled waste disposal, please separate this from other types of wastes and recycle it responsibly to promote the sustainable reuse of material resources.

Household users should contact either the retailer where they purchased this product, or their local government office, for details of where and how they can take this item for environmentally safe recycling.

Business users should contact their supplier and check the terms and conditions of the purchase contract. This product should not be mixed with other commercial wastes for disposal.

### Head Office & Energy Showrooms:

ATC House, Broomhill Drive,  
Tallaght, D24 EF99  
Ireland.  
Tel: 353 (1) 467 8301

UK Tel: 0044 (0)203 5649164  
Email: sales@atc.ie

**atc**  
**Smart**